



DIRECT DECK SKIN & PONTOON ALUMINUM INTERNAL FLOATING ROOF

DirecTank's **Direct Deck** Internal Floating Roof is a reliable, efficient, and adaptable internal floating cover option. Featuring high-quality, robust aluminum components, this conventional skin and pontoonaluminum IFR is a cost effective solution and reliable floating cover option.

Both leg-supported and cable-suspended options are available, as are hybrid aluminum-stainless steel and all-stainless steel options. Additionally, the **Direct Deck** is available in both 500 and 1000 models, depending upon specifications and requirements. These models are based upon the API Standard 650 structural design requirements, with the 1000 featuring additional reinforcement for enhanced structural strength. Furthermore, the **Direct Deck** can be easily customized as required to meet the most stringent and unique specifications.

The **Direct Deck** will accommodate a varying range of service conditions, and is equipped with a custom-designed primary seal (mechanical shoe or wiper), with secondary seal and foam dam options, designed to operate efficiently in conjunction with the roof to provide a system with the superior flexibility required to handle reasonable operational and dynamic loads and high cycle frequencies.

Every **Direct Deck** is designed by our engineering team using the data provided and subjected to our rigorous, industry-best quality assurance program.

The **Direct Deck** combines sound engineering, proven technology, and installer-friendly enhancements, all at an economical price with the best lead time and warranty in the industry.

For more information, contact our expert team at 713-673-7701 (Toll Free 800-720-6629) or email sales@directtank.com



Features & Benefits

- Designed in full accordance with API standard 650
- Customized configuration for optimum performance
- Extremely durable with excellent working range
- Versatile, robust design providing continuous, worry-free operation
- Full traceability on manufacturing and materials independently certified with 3rd party validation
- Simple, safe installation with all-bolted connections and no necessary hot-work
- All components designed to fit through a standard 20" diameter shell manway
- Available as either leg or cable supported
- Available in all-aluminum, all-stainless steel, and aluminum-stainless steel hybrid options
- Full compliance with all relevant codes and regulations, including the EPA 40 CFR 60 and local AQMD requirements

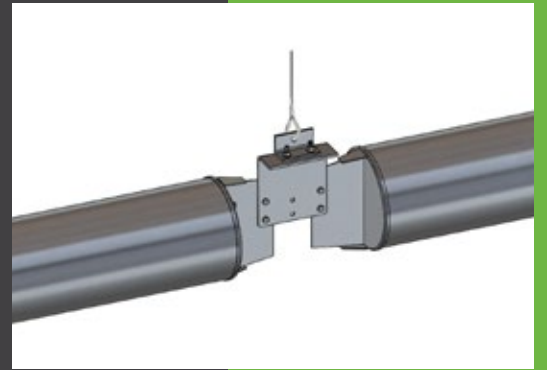



About DirecTank

At DirecTank we maintain one of the largest and most diverse inventories in the industry, reinforced by a robust global supply chain management system. We pride ourselves on being truly customer-focused, with a commitment to high-quality, competitively-priced products delivered within the shortest lead time in the industry. We are the most diverse aboveground storage tank (AST) products company in the business, merging cutting-edge ideas with over 100 years of collective experience that has been acquired from all phases of the AST industry.

DirecTank is a proud member of the DSS Group of Companies, privately owned and operated in Houston, Texas, and we are committed to becoming the most trusted AST Products company in the industry.

 6059 South Loop East
Houston, TX 77087

 713-673-7701
800-720-6629 Toll Free

 sales@directank.com
www.directank.com